

NAT-AMC-CCT7

AMC CARRIER WITH TYPE7 COMEXPRESS MODULE

DESIGNED BY N.A.T. GMBH

TECHNICAL REFERENCE MANUAL V2.1

HW REVISION 2.X

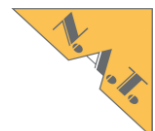

TABLE OF CONTENTS

1. PREFACE	5
1.1. Disclaimer.....	5
1.2. About This Document.....	6
2. INTRODUCTION	7
2.1. Main Features	8
3. QUICK START	9
3.1. Unpacking	9
3.2. Mechanical Requirements.....	9
3.3. Voltage Requirements	10
3.3.1. POWER SUPPLY.....	10
3.3.2. HOT-SWAP	10
4. FUNCTIONAL DESCRIPTION	11
4.1. M.2 Interface	12
4.2. Memory	12
4.3. Gigabit Ethernet Controller and Multiplexing.....	12
4.4. MMC	12
4.5. Front Panel Interfaces.....	12
4.5.1. GRAPHICAL INTERFACE.....	12
4.5.2. USB INTERFACE.....	12
4.5.3. ETHERNET PORT	12
4.5.4. SFP28 INTERFACE.....	13
4.5.5. DEBUG INTERFACE.....	13
5. HARDWARE	14
5.1. Front Panel and LEDs.....	14
5.2. Connector- and Switch-Location.....	15
5.2.1. J2 A/B AND J2 C/D: COMEXPRESS MODULE CONNECTORS.....	18
5.2.2. S1: AMC EDGE CONNECTOR.....	23
5.2.3. SW1: SWITCH.....	26
5.2.4. SW2: HOT-SWAP-SWITCH	26



5.2.5. SW3: BOOT MODE SELECT SWITCH 26

6. SPECIFICATIONS AND COMPLIANCES 27

6.1. Internal Reference Documentation..... 27

6.2. Standards Compliance 27

6.3. Compliance to RoHS Directive 28

6.4. Compliance to WEEE Directive 28

6.5. Compliance to CE Directive..... 29

6.6. Compliance to REACH 29

6.7. Abbreviation List..... 29

7. DOCUMENT’S HISTORY 30



LIST OF TABLES

TABLE 1 – MAIN FEATURES.....	8
TABLE 2 – FRONT PANEL LEDs.....	14
TABLE 3 – CONNECTOR LABELLING AND FUNCTION.....	16
TABLE 4 – J2 A/B: COMEXPRESS MODULE CONNECTOR – PIN ASSIGNMENT.....	18
TABLE 5 – J2 C/D: COMEXPRESS MODULE CONNECTOR – PIN ASSIGNMENT.....	20
TABLE 6 – S1: AMC EDGE CONNECTOR – PIN ASSIGNMENT.....	23
TABLE 7 – SW1: SWITCH– OPERATING PARAMETERS.....	26
TABLE 8 – SW3: BOOT MODE SELECT SWITCH– OPERATING PARAMETERS.....	26
TABLE 9 – ABBREVIATION LIST.....	29
TABLE 10 – DOCUMENT’S HISTORY.....	30

LIST OF FIGURES

FIGURE 1 – BLOCK DIAGRAM NAT-AMC-CCT7.....	11
FIGURE 2 – NAT-AMC-CCT7: FRONT PANEL.....	14
FIGURE 3 – NAT-AMC-CCT7 – LOCATION DIAGRAM – TOP.....	15
FIGURE 4 - NAT-AMC-CCT7 – LOCATION DIAGRAM – BOTTOM.....	16
FIGURE 5 – J2 A/B AND J2 C/D: COMEXPRESS MODULE CONNECTORS.....	18
FIGURE 6 – S1: AMC EDGE CONNECTOR (TOP VIEW).....	23
FIGURE 7 – SW1: SWITCH.....	26
FIGURE 8 – SW500: BOOT MODE SELECT SWITCH.....	26



1. PREFACE

1.1. Disclaimer

The following documentation, compiled by N.A.T. GmbH (henceforth called N.A.T.), represents the current status of the product's development. The documentation is updated on a regular basis. Any changes which might ensue, including those necessitated by updated specifications, are considered in the latest version of this documentation. N.A.T. is under no obligation to notify any person, organization, or institution of such changes or to make these changes public in any other way.

We must caution you, that this publication could include technical inaccuracies or typographical errors.

N.A.T. offers no warranty, either expressed or implied, for the contents of this documentation or for the product described therein, including but not limited to the warranties of merchantability or the fitness of the product for any specific purpose.

In no event will N.A.T. be liable for any loss of data or for errors in data utilization or processing resulting from the use of this product or the documentation. In particular, N.A.T. will not be responsible for any direct or indirect damages (including lost profits, lost savings, delays or interruptions in the flow of business activities, including but not limited to, special, incidental, consequential, or other similar damages) arising out of the use of or inability to use this product or the associated documentation, even if N.A.T. or any authorized N.A.T. representative has been advised of the possibility of such damages.

All registered names, trademarks etc. are property of their respective holders. The use of registered names, trademarks, etc. in this publication does not imply, even in the absence of a specific statement, that such names are exempt from the relevant protective laws and regulations (patent laws, trade mark laws, etc.) and therefore free for general use. In no case does N.A.T. guarantee that the information given in this documentation is free of such third-party rights.

Neither this documentation nor any part thereof may be copied, translated, or reduced to any electronic medium or machine form without the prior written consent from N.A.T. GmbH.

This product (and the associated documentation) is governed by the N.A.T. General Conditions and Terms of Delivery and Payment.

Note:

The release of the Hardware Manual is related to a certain HW board revision given in the document title. For HW revisions earlier than the one given in the document title please contact N.A.T. for the corresponding older Hardware Manual release.

1.2. About This Document

This document is intended to give an overview on the **NAT-AMC-CCT7's** functional capabilities.

Preface

General information about this document

Introduction

Abstract on the **NAT-AMC-CCT7's** main functionality and application field

Quick Start

Important information and mandatory requirements to be considered before operating the **NAT-AMC-CCT7** for the first time

Functional Description

Detailed information on the individual devices and the **NAT-AMC-CCT7's** main features

Hardware

Information about LEDs and connectors

Specifications and Compliances

Detailed list of specifications, abbreviations, and datasheets of components referred to in this document, as well as standards, the **NAT-AMC-CCT7** complies to

Document's History

Revision record

Note:

It is assumed, that the **NAT-AMC-CCT7** is handled by qualified personnel only!



2. INTRODUCTION

Generally, the **NAT-AMC-CCT7** is an COMExpress (COMex) carrier module in double-width and full-size AMC form factor. In combination with a compliant COMex module, it works as a general-purpose processor (PrAMC), storage, and graphic AMC.

The **NAT-AMC-CCT7** supports any COMex module Type7 validated by NAT. It offers PCIe Gen4 x8 at ports 4-11 and 12-20 at the backplane. Moreover, it provides 2x 10G Ethernet via port0/1, 2x 25G Ethernet via SFP28 front uplink, and a 1G Ethernet link via RJ45 at the front panel.

One M.2 PCIe x4 interface is intended for mounting a memory device, a second one can be equipped with a graphic card. If so, the board provides an HDMI interface at the front panel.

Thus, the **NAT-AMC-CCT7** offers a wide range of setups from well-priced to high-performing configurations.

2.1. Main Features

Table 1 – Main Features

Form Factor	
	<ul style="list-style-type: none"> • Double-width, full-size AMC • Width: 147 mm, Depth: <180.6 mm
Mounting Slot	
	<ul style="list-style-type: none"> • For any type of COMExpress-Type 7 module validated by N.A.T.
On-Board Resources COMex Type-7	
MMC	<ul style="list-style-type: none"> • Microchip ATxmega128
Ethernet Controller	<ul style="list-style-type: none"> • Dual 25G Intel Ethernet Controller E810-XXVAM2
Storage	<ul style="list-style-type: none"> • MicroSD-Card • M.2 PCIe x4 memory interface for SSD, FLASH
Graphic	<ul style="list-style-type: none"> • M.2 PCIe x4 graphic module (option)
Front Panel Connections	<ul style="list-style-type: none"> • HDMI port (option) • 4x USB 3.0 • 1x 1G Ethernet vis RJ45 • 2x SFP28 (25G Ethernet) • Debug
Backplane Interconnect	<ul style="list-style-type: none"> • IPMI • AMC Port 0/1: 10G-KR • AMC Port 2/3: SAS / SATA • AMC Port 4-11 / 12-20: PCIe x8 Gen4 • TCKLA-D
LEDs	
	<ul style="list-style-type: none"> • Standard AMC LEDs (Status, Fault, Hot-Swap)
Compliance	
	<ul style="list-style-type: none"> • MTCA.0 / MTCA.4 • AMC.0 • AMC.1 • AMC.2 • IMPI V2.0 • HPM.1
Environmental	
Operating Environment	<ul style="list-style-type: none"> • default: 0 to +50 degrees Celsius • Humidity: 5% to 95% (non-condensing)
Storage Environment	<ul style="list-style-type: none"> • default: -40 to +100 degrees Celsius • Humidity: 5% to 95% (non-condensing)
Order Codes: NAT-AMC-CCT7 – [Option]	
-XE32	<ul style="list-style-type: none"> • double width full size COMex carrier for Type7 modules. With 4+1 USB ports, 2 SFP+ ports to front, option for M2 memory, min 2* 1 GbE to Port 0&1, x8/x16 lanes PCIe to backplane equipped with Type7 XEON CPU and 2*16GB RAM ECC based on MTCA.0 AMC
-CE16	<ul style="list-style-type: none"> • double width full size COMex carrier for Type 7 modules. With 4+1 USB ports, 2 SFP+ ports to front, option for M2 Memory, min 2* 1 GbE to Port 0&1, x8/x16 lanes PCIe to backplane equipped with Type7 Celeron CPU and 16 GB RAM ECC based on MTCA.0 AMC

3. QUICK START

To ensure proper functioning of the **NAT-AMC-CCT7** during its usual lifetime, take the following precautions before handling the board.

3.1. Unpacking

Electrostatic discharge, incorrect board installation and uninstallation can damage circuits or shorten their lifetime. Before touching integrated circuits, ensure to take all required precautions for handling electrostatic devices.

Avoid touching gold contacts of the connectors to ensure proper contact when connecting the **NAT-AMC-CCT7** to the MTCA-System.

Make sure that the board and its attachments are undamaged and complete according to delivery note.

3.2. Mechanical Requirements

The installation requires a MicroTCA backplane, a power supply, and cooling devices.

Before installing or uninstalling the **NAT-AMC-CCT7**, read the Installation Guide and the User's Manual of the **NAT-AMC-CCT7** and the μ TCA system the board will be plugged into.

Check all installed boards and modules for steps that you have to take before turning on or off the power. After taking those steps, turn on or off the power if necessary.

Make sure the part to be installed / removed is Hot-Swap capable, if you don't switch off the power.

Ensure that the **NAT-AMC-CCT7** is connected with the connector(s) completely inserted.

When operating the board in areas of strong electromagnetic radiation, ensure that the module is bolted to the rear panel or rack, and shielded by closed housing.

3.3. Voltage Requirements

3.3.1. Power supply

The power supply for the **NAT-AMC-CCT7** must meet the following specifications:

Carrier Board: +12V / 0.5A max. (without COMex module)

Additional power consumption according to attached COM Express module

3.3.2. Hot-Swap

The **NAT-AMC-CCT7** supports hot-swapping, which means that the board can be inserted or extracted during normal system operation without affecting other modules.

Make sure to follow the procedure **exactly** to prevent the **NAT-AMC-CCT7** or the system it is plugged into from damage!

Insertion of a hot-swap-capable module

- Ensure the module and the backplane support hot-swapping
- Ensure that the hot-swap-handle is in "unlock"-position (pulled out)
- Push the **NAT-AMC-CCT7** carefully into the dedicated connector until it is completely inserted
- The blue HS-LED turns solid on
- With pushing the hot-swap-handle to "lock"-position, the HS-LED starts blinking and the IPMI-Controller of the backplane detects the board
- If the information provided by the **NAT-AMC-CCT7** is valid, the backplane enables payload power and the blue HS-LED turns off

Extraction of a hot-swap-capable module

- Pull the hot-swap-handle in "unlock"-position
- The blue HS-LED starts blinking
- The IPMI-Controller of the backplane disables payload power
- The HS-LED turns solid on
- Pull the **NAT-AMC-CCT7** carefully out of the backplane



4. FUNCTIONAL DESCRIPTION

Essentially, the **NAT-AMC-CCT7** works as COMExpress carrier module, so the board itself does not include too many complex functional blocks. Hence the block diagrams below show the interwork with a COMExpress module only.

The following figures give an overview of the functional blocks.

Figure 1 – Block Diagram NAT-AMC-CCT7

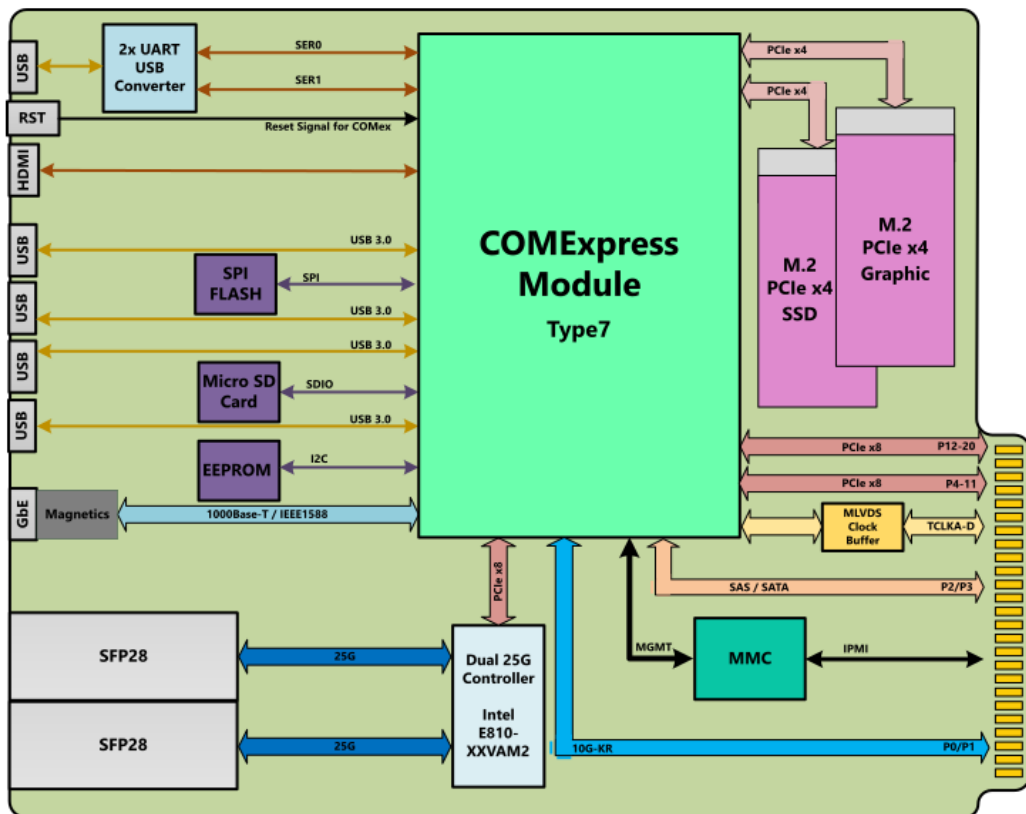

4.1. M.2 Interface

Originally, the M.2 interface was intended as pure mass storage interface, but meanwhile also solutions for connecting e.g. an LTE- or WIFI-module are available.

The **NAT-AMC-CCT7** owns two M.2 interfaces; one is intended to be used with an SSD or FLASH memory, and a second M.2 interface can be equipped with a graphic module. In this case, the carrier provides an HDMI interface at the front panel.

4.2. Memory

SPI FLASH, EEPROM (both for internal use), and a MicroSD-Card are attached to the COMex module.

4.3. Gigabit Ethernet Controller and Multiplexing

The **NAT-AMC-CCT7** features an Intel E810-XXVAM2 Dual 25G Ethernet Controller. This controller is connected via an PCIe x8 link to the COMex module and provides 25G Ethernet to the SFP28 interfaces at the front panel.

10G Ethernet to Port 0/1 is directly connected to the COMex module as well as the SerDes PCIe Gen4 x8 connections at Port 4-11 and Port 12-20. Moreover, SAS / SATA to Port 2/3 is supported.

4.4. MMC

A Microchip ATxmega128 works as Module Management Controller (MMC).

4.5. Front Panel Interfaces

4.5.1. Graphical Interface

If an M.2 graphic module is installed, an HDMI connector provides a graphical interface at the front panel.

4.5.2. USB Interface

The **NAT-AMC-CCT7** features four USB 3.0 interfaces at the front panel.

4.5.3. Ethernet Port

The **NAT-AMC-CCT7** features a 1000Base-T interface at the front panel via an RJ45 connector.



4.5.4. SFP28 Interface

The **NAT-AMC-CCT7** provides a dual SFP28 interface with up to 25G Ethernet at the front panel.

4.5.5. Debug Interface

Per default, both interfaces of the USB-to-UART bridge are connected to the two serial ports of the COMExpress module (CE_SER1 and CE_SER0).

The debug interface is accessible via a Micro-USB connector at the front panel.

5. HARDWARE

5.1. Front Panel and LEDs

The NAT-AMC-CCT7 is equipped with various LEDs described in the following section.

Figure 2 – NAT-AMC-CCT7: Front Panel

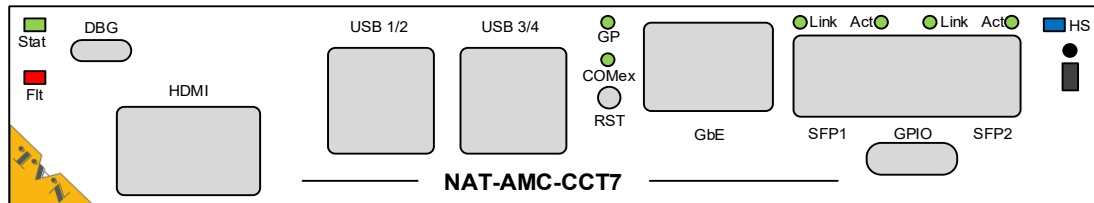

Table 2 – Front Panel LEDs

Label	Color	Behaviour	Description
SFP 1/2 Link	green	Fast flash	25G
		Slow blink	10G
		OFF	No link available
SFP 1/2 Act	green	Solid ON	SFP interface active
		OFF	SFP interface inactive
COMex	green	Solid ON	COMex active
		OFF	COMex inactive
GP	green	tbd	controlled by Microcontroller
Stat	green		General purpose status LED
	orange		controlled by Microcontroller
Flt	red	Solid ON	Fault LED: temperature exceeds range
HS	blue		Hot-Swap LED refer to chapter 3.3.2 Hot-Swap

Two LEDs integrated in the RJ45 Ethernet jack are driven directly by the COMExpress GBE0_LINK#, GBE0_LINK100#, GBE0_LINK1000n, and GBE0_ACT# signals.

5.2. Connector- and Switch-Location

Figure 3 – NAT-AMC-CCT7 – Location Diagram – Top

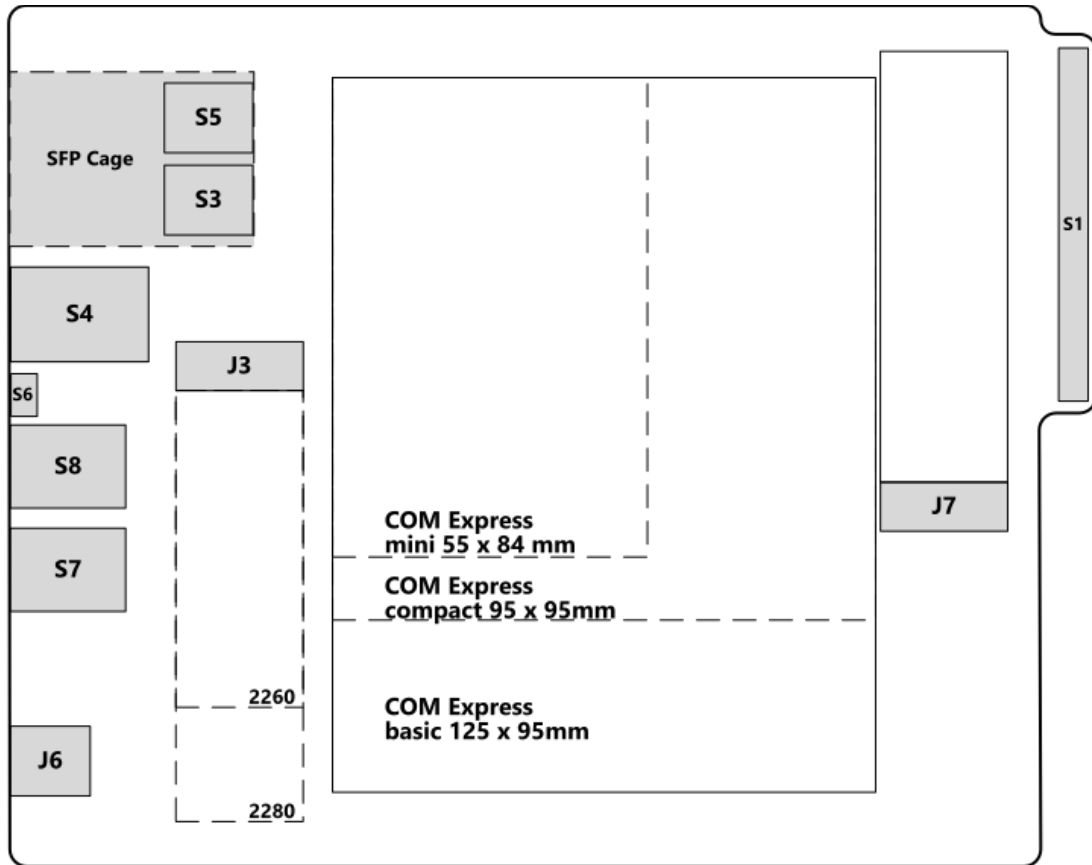
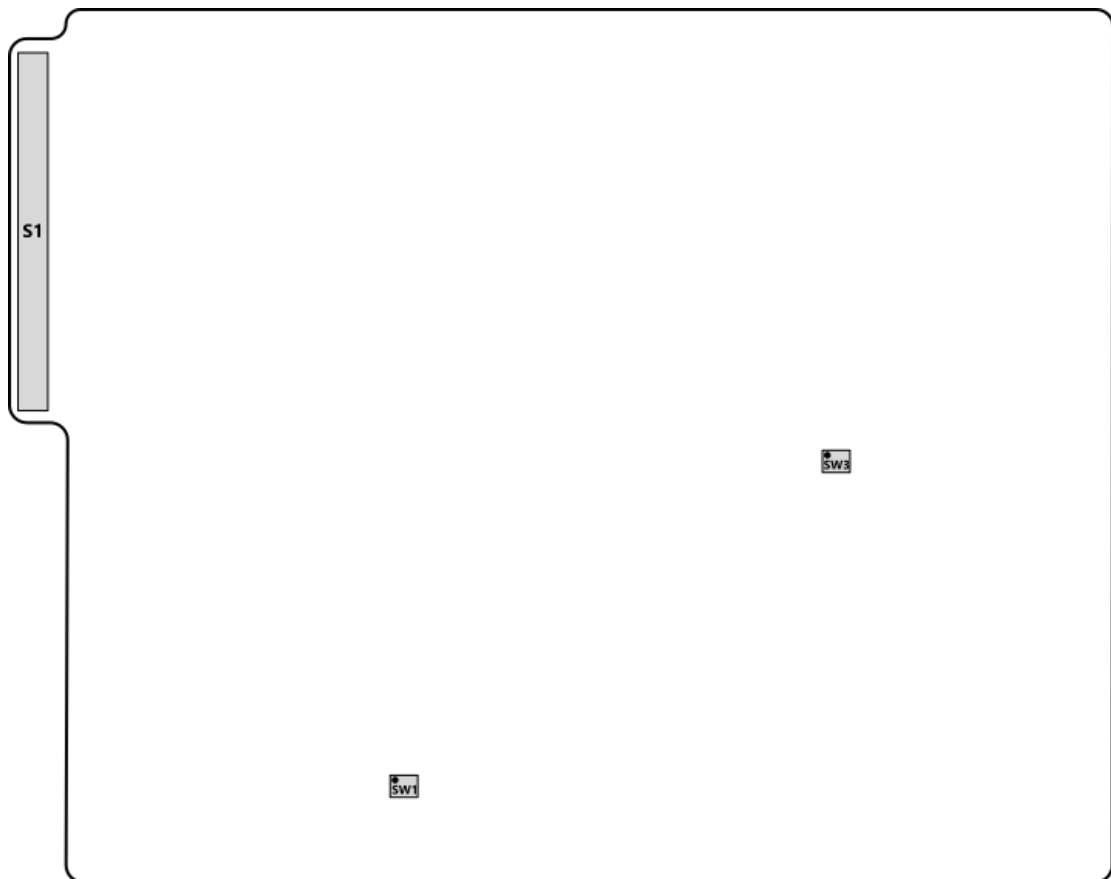

Figure 4 - NAT-AMC-CCT7 – Location Diagram – Bottom



Assignments from connector labelling to function can be found in the table below.

Table 3 – Connector Labelling and Function

Label	Description
J2 A-D (below COMex)	Connectors to COMex Module
J3	M.2 Interface for mass storage device via NVME-PCIe bus with a length of 60 or 80mm
J6	Debug Interface via Micro-USB B
J7	M.2 Interface for graphic module
S1	Standard AMC-Edge Connector
S3 + S5	SFP28 Interfaces
S4	RJ45 Connector
S6	Reset Switch
S7 + S8	2x 2 USB 3.0 Type A Recepts
SW1	Dual Dip Switch, connected to MMC
SW3	Dual Dip Switch for Boot Select

For standard interfaces, no further explanation is given. Please refer to the particular standards for more information.

Pin assignments and drawings of non-standard interfaces are described in the following paragraphs.

Connectors on top side: drawings imply the board is orientated with the AMC connector to the *right* side

Connectors on bottom side: drawings imply the board is orientated with the AMC connector to the *left* side

5.2.1. J2 A/B and J2 C/D: COMExpress Module Connectors

Connectors J2 A/B and J1 C/D connect the COMExpress module to the carrier board.

Figure 5 – J2 A/B and J2 C/D: COMExpress Module Connectors

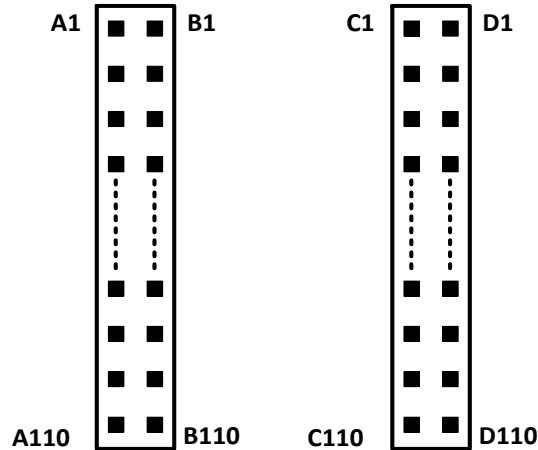

Table 4 – J2 A/B: COMExpress Module Connector – Pin Assignment

Pin #	Signal	Signal	Pin #
A1	GND	GND	B1
A2	GBE0_MDI3_N	GBE0_ACTn	B2
A3	GBE0_MDI3_P	nc	B3
A4	GBE0_LINK100n	nc	B4
A5	GBE0_LINK1000n	nc	B5
A6	GBE0_MDI2_N	nc	B6
A7	GBE0_MDI2_P	nc	B7
A8	GBE0_LINKn	nc	B8
A9	GBE0_MDI1_N	nc	B9
A10	GBE0_MDI1_P	nc	B10
A11	GND	GND	B11
A12	GBE0_MDI0_N	CE_PWRBTN#	B12
A13	GBE0_MDI0_P	CE_SMB_CLK	B13
A14	GBE0_CTREF	CE_SMB_DAT	B14
A15	CE_SUS_S3#	SMB_ALERTn	B15
A16	nc	nc	B16
A17	nc	nc	B17
A18	CE_SUS_S4#	CE_SUS_STAT#	B18
A19	nc	nc	B19
A20	nc	nc	B20
A21	GND	GND	B21
A22	nc	nc	B22
A23	nc	nc	B23
A24	CE_SUS_S5#	CE_PWR_OK	B24
A25	nc	nc	B25
A26	nc	nc	B26

Pin #	Signal	Signal	Pin #
A27	CE_BATLOW#	nc	B27
A28	ATA_ACT#	nc	B28
A29	nc	nc	B29
A30	nc	nc	B30
A31	GND	GND	B31
A32	nc	SPEAKER	B32
A33	nc	CE_I2C_CK	B33
A34	CE_BIOS_DIS0n	CE_I2C_DAT	B34
A35	CE_THRMTRIP#	CE_THRM#	B35
A36	nc	nc	B36
A37	nc	nc	B37
A38	nc	nc	B38
A39	nc	nc	B39
A40	nc	nc	B40
A41	GND	GND	B41
A42	USB2_N	USB3_N	B42
A43	USB2_P	USB3_P	B43
A44	USB_2_3_OCn	USB_0_1_OCn	B44
A45	USB0_N	USB1_N	B45
A46	USB0_P	USB1_P	B46
A47	VCC_RTC	nc	B47
A48	nc	nc	B48
A49	nc	CE_SYS_RESET#	B49
A50	nc	CE_CB_RESET#	B50
A51	GND	GND	B51
A52	nc	nc	B52
A53	nc	nc	B53
A54	SD_DATA0	SD_CMD	B54
A55	PCIE1-TX0_P	PCIE1-RX0_P	B55
A56	PCIE1-TX0_N	PCIE1-RX0_N	B56
A57	GND	SD_WP	B57
A58	PCIE0-TX3_P	PCIE0-RX3_P	B58
A59	PCIE0-TX3_N	PCIE0-RX3_N	B59
A60	GND	GND	B60
A61	PCIE0-TX2_P	PCIE0-RX2_P	B61
A62	PCIE0-TX2_N	PCIE0-RX2_N	B62
A63	SD_DATA1	SD_CDn	B63
A64	PCIE0-TX1_P	PCIE1-Rx+	B64
A65	PCIE0-TX1_N	PCIE1-Rx-	B65
A66	GND	WAKE0#	B66
A67	SD_DATA2	WAKE1#	B67
A68	PCIE0-TX0_P	PCIE0-RX0_P	B68
A69	PCIE0-TX0_N	PCIE0-RX0_N	B69
A70	GND	GND	B70
A71	nc	nc	B71
A72	nc	nc	B72
A73	nc	nc	B73
A74	nc	nc	B74
A75	nc	nc	B75
A76	nc	nc	B76



Pin #	Signal	Signal	Pin #
A77	nc	nc	B77
A78	nc	nc	B78
A79	nc	nc	B79
A80	GND	GND	B80
A81	nc	nc	B81
A82	nc	nc	B82
A83	nc	nc	B83
A84	nc	+5V	B84
A85	SD_DATA3	+5V	B85
A86	nc	+5V	B86
A87	nc	+5V	B87
A88	PCIE_CLK_REF_P	CE_BIOS_DIS1n	B88
A89	PCIE_CLK_REF_N	nc	B89
A90	GND	GND	B90
A91	SPI_PWR	nc	B91
A92	CE_SPI_MISO	nc	B92
A93	SD_CLK	nc	B93
A94	CE_SPI_CLK	nc	B94
A95	CE_SPI_MOSI	nc	B95
A96	nc	nc	B96
A97	CE_TYPE10n	CE_SPI_CSn	B97
A98	CE_SER0_TX	nc	B98
A99	CE_SER0_RX	nc	B99
A100	GND	GND	B100
A101	CE_SER1_TX	nc	B101
A102	CE_SER1_RX	nc	B102
A103	nc	#SLEEP	B103
A104	+12V_CE	+12V_CE	B104
A105	+12V_CE	+12V_CE	B105
A106	+12V_CE	+12V_CE	B106
A107	+12V_CE	+12V_CE	B107
A108	+12V_CE	+12V_CE	B108
A109	+12V_CE	+12V_CE	B109
A110	GND	GND	B110

Table 5 – J2 C/D: COMExpress Module Connector – Pin Assignment

Pin #	Signal	Signal	Pin #
C1	GND	GND	D1
C2	GND	GND	D2
C3	USB0_SSRX_N	USB0_SSTX_N	D3
C4	USB0_SSRX_P	USB0_SSTX_P	D4
C5	GND	GND	D5
C6	USB1_SSRX_N	USB1_SSTX_N	D6
C7	USB1_SSRX_P	USB1_SSTX_P	D7
C8	GND	GND	D8
C9	USB2_SSRX_N	USB2_SSTX_N	D9
C10	USB2_SSRX_P	USB2_SSTX_P	D10
C11	GND	GND	D11

Pin #	Signal	Signal	Pin #
C12	USB3_SSRX_N	USB3_SSTX_N	D12
C13	USB3_SSRX_P	USB3_SSTX_P	D13
C14	GND	GND	D14
C15	nc	DDI1_AUX_P	D15
C16	nc	DDI1_AUX_N	D16
C17	nc	nc	D17
C18	nc	nc	D18
C19	PCIE1-RX2_P	PCIE1-TX2_P	D19
C20	PCIE1-RX2_N	PCIE1-TX2_N	D20
C21	GND	GND	D21
C22	PCIE1-RX3_P	PCIE1-TX3_P	D22
C23	PCIE1-RX3_N	PCIE1-TX3_N	D23
C24	DDI1_HPDP	nc	D24
C25	nc	nc	D25
C26	10G_KR3_RX_P	DDI1_PAIR0_P	D26
C27	10G_KR3_RX_N	DDI1_PAIR0_N	D27
C28	nc	nc	D28
C29	10G_KR2_RX_P	DDI1_PAIR1_P	D29
C30	10G_KR2_RX_N	DDI1_PAIR1_N	D30
C31	GND	GND	D31
C32	nc	DDI1_PAIR2_P	D32
C33	nc	DDI1_PAIR2_N	D33
C34	nc	DDI1_DDC_AUX_SEL_R	D34
C35	nc	10G_PHY_CAP01	D35
C36	nc	DDI1_PAIR3_P	D36
C37	nc	DDI1_PAIR3_N	D37
C38	10G_KR1_SFP_SDA	10G_KR1_SFP_SCL	D38
C39	10G_KR0_SFP_SDA	10G_KR0_SFP_SCL	D39
C40	nc	nc	D40
C41	GND	GND	D41
C42	10G_KR1_RX_P	10G_KR1_TX_P	D42
C43	10G_KR1_RX_N	10G_KR1_TX_N	D43
C44	nc	nc	D44
C45	nc	nc	D45
C46	nc	nc	D46
C47	nc	nc	D47
C48	nc	nc	D48
C49	10G_KR0_RX_P	10G_KR0_TX_P	D49
C50	10G_KR0_RX_N	10G_KR0_TX_N	D50
C51	GND	GND	D51
C52	PORT4-Rx_P	PORT4-Tx_P	D52
C53	PORT4-Rx_N	PORT4-Tx_N	D53
C54	CE_TYPE0n	GND	D54
C55	PORT5-Rx_P	PORT5-Tx_P	D55
C56	PORT5-Rx_N	PORT5-Tx_N	D56
C57	CE_TYPE1n	CE_TYPE2n	D57
C58	PORT6-Rx_P	PORT6-Tx_P	D58
C59	PORT6-Rx_N	PORT6-Tx_N	D59
C60	GND	GND	D60
C61	PORT7-Rx_P	PORT7-Tx_P	D61

Pin #	Signal	Signal	Pin #
C62	PORT7-Rx_N	PORT7-Tx_N	D62
C63	nc	nc	D63
C64	nc	nc	D64
C65	PORT8-Rx_P	PORT8-Tx_P	D65
C66	PORT8-Rx_N	PORT8-Tx_N	D66
C67	RAPID_SHUTDOWN	GND	D67
C68	PORT9-Rx_P	PORT9-Tx_P	D68
C69	PORT9-Rx_N	PORT9-Tx_N	D69
C70	GND	GND	D70
C71	PORT10-Rx_P	PORT10-Tx_P	D71
C72	PORT10-Rx_N	PORT10-Tx_N	D72
C73	GND	GND	D73
C74	PORT11-Rx_P	PORT11-Tx_P	D74
C75	PORT11-Rx_N	PORT11-Tx_N	D75
C76	GND	GND	D76
C77	nc	nc	D77
C78	PORT12-Rx_P	PORT12-Tx_P	D78
C79	PORT12-Rx_N	PORT12-Tx_N	D79
C80	GND	GND	D80
C81	PORT13-Rx_P	PORT13-Tx_P	D81
C82	PORT13-Rx_N	PORT13-Tx_N	D82
C83	nc	nc	D83
C84	GND	GND	D84
C85	PORT14-Rx_P	PORT14-Tx_P	D85
C86	PORT14-Rx_N	PORT14-Tx_N	D86
C87	GND	GND	D87
C88	PORT15-Rx_P	PORT15-Tx_P	D88
C89	PORT15-Rx_N	PORT15-Tx_N	D89
C90	GND	GND	D90
C91	PORT17-Rx_P	PORT17-Tx_P	D91
C92	PORT17-Rx_N	PORT17-Tx_N	D92
C93	GND	GND	D93
C94	PORT18-Rx_P	PORT18-Tx_P	D94
C95	PORT18-Rx_N	PORT18-Tx_N	D95
C96	GND	GND	D96
C97	nc	nc	D97
C98	PORT19-Rx_P	PORT19-Tx_P	D98
C99	PORT19-Rx_N	PORT19-Tx_N	D99
C100	GND	GND	D100
C101	PORT20-Rx_P	PORT20-Rx_P	D101
C102	PORT20-Rx_N	PORT20-Rx_N	D102
C103	GND	GND	D103
C104	+12V_CE	+12V_CE	D104
C105	+12V_CE	+12V_CE	D105
C106	+12V_CE	+12V_CE	D106
C107	+12V_CE	+12V_CE	D107
C108	+12V_CE	+12V_CE	D108
C109	+12V_CE	+12V_CE	D109
C110	GND	GND	D110



5.2.2. S1: AMC Edge Connector

The NAT-AMC-CCT7 connects to the backplane via S1.

Figure 6 – S1: AMC Edge Connector (top view)

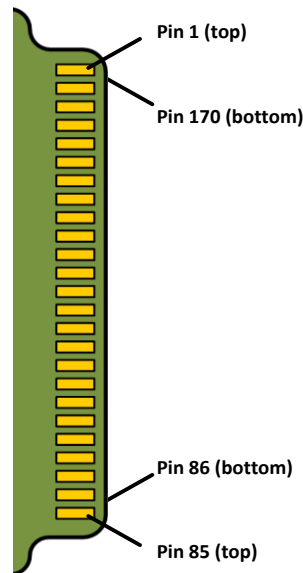

Table 6 – S1: AMC Edge Connector – Pin Assignment

Pin #	Signal	Signal	Pin #
1	GND	GND	170
2	+12V_PP	nc	169
3	/AMC_PS1	nc	168
4	+3.3V_MP	nc	167
5	AMC_GA0	nc	166
6	nc	nc	165
7	GND	GND	164
8	nc	PORT20-Tx_R_P	163
9	+12V_PP	PORT20-Tx_R_N	162
10	GND	GND	161
11	PORT0-Tx_P	PORT20-Rx_R_P	160
12	PORT0-Tx_N	PORT20-Rx_R_N	159
13	GND	GND	158
14	PORT0-Rx_P	PORT19-Tx_R_P	157
15	PORT0-Rx_N	PORT19-Tx_R_N	156
16	GND	GND	155
17	AMC_GA1	PORT19-Rx_R_P	154
18	+12V_PP	PORT19-Rx_R_N	153
19	GND	GND	152
20	PORT1-Tx_P	PORT18-Tx_R_P	151
21	PORT1-Tx_N	PORT18-Tx_R_N	150
22	GND	GND	149
23	PORT1-Rx_P	PORT18-Rx_R_P	148

Pin #	Signal	Signal	Pin #
24	PORT1-Rx_N	PORT18-Rx_R_N	147
25	GND	GND	146
26	AMC_GA2	PORT17-Tx_R_P	145
27	+12V_PP	PORT17-Tx_R_N	144
28	GND	GND	143
29	PORT2-Tx_P	PORT17-Rx_R_P	142
30	PORT2-Tx_N	PORT17-Rx_R_N	141
31	GND	GND	140
32	PORT2-Rx_P	nc	139
33	PORT2-Rx_N	nc	138
34	GND	GND	137
35	PORT3-Tx_P	nc	136
36	PORT3-Tx_N	nc	135
37	GND	GND	134
38	PORT3-Rx_P	PORT15-Tx_R_P	133
39	PORT3-Rx_N	PORT15-Tx_R_N	132
40	GND	GND	131
41	AMC_ENABLEn	PORT15-Rx_R_P	130
42	+12V_PP	PORT15-Rx_R_N	129
43	GND	GND	128
44	PORT4-Tx_P	PORT14-Tx_R_P	127
45	PORT4-Tx_N	PORT14-Tx_R_N	126
46	GND	GND	125
47	PORT4-Rx_P	PORT14-Rx_R_P	124
48	PORT4-Rx_N	PORT14-Rx_R_N	123
49	GND	GND	122
50	PORT5-Tx_P	PORT13-Tx_R_P	121
51	PORT5-Tx_N	PORT13-Tx_R_N	120
52	GND	GND	119
53	PORT5-Rx_P	PORT13-Rx_R_P	118
54	PORT5-Rx_N	PORT13-Rx_R_N	117
55	GND	GND	116
56	AMC_SCL	PORT12-Tx_R_P	115
57	+12V_PP	PORT12-Tx_R_N	114
58	GND	GND	113
59	PORT6-Tx_P	PORT12-Rx_R_P	112
60	PORT6-Tx_N	PORT12-Rx_R_N	111
61	GND	GND	110
62	PORT6-Rx_P	PORT11-Tx_P	109
63	PORT6-Rx_N	PORT11-Tx_N	108
64	GND	GND	107
65	PORT7-Tx_P	PORT11-Rx_P	106
66	PORT7-Tx_N	PORT11-Rx_N	105
67	GND	GND	104
68	PORT7-Rx_P	PORT10-Tx_P	103
69	PORT7-Rx_N	PORT10-Tx_N	102
70	GND	GND	101
71	AMC_SDA	PORT10-Rx_P	100
72	+12V_PP	PORT10-Rx_N	99
73	GND	GND	98

Pin #	Signal	Signal	Pin #
74	AMC_TCLKA_P	PORT9-Tx_P	97
75	AMC_TCKLA_N	PORT9-Tx_N	96
76	GND	GND	95
77	AMC_TCLKB_P	PORT9-Rx_P	94
78	AMC_TCKLB_N	PORT9-Rx_N	93
79	GND	GND	92
80	AMC_FCLKA_P	PORT8_Tx_P	91
81	AMC_FCKLA_N	PORT8-Tx_N	90
82	GND	GND	89
83	/AMC_PSO	PORT8-Rx_P	88
84	+12V_PP	PORT8-Rx_N	87
85	GND	GND	86



5.2.3. SW1: Switch

SW1 is connected to the MMC, the function of SW1 is tbd

Figure 7 – SW1: Switch



Table 7 – SW1: Switch– Operating Parameters

SW1-1	SW1-2	Function
OFF	OFF	tbd
ON	OFF	tbd
OFF	ON	tbd
OFF	OFF	tbd

5.2.4. SW2: Hot-Swap-Switch

Switch SW1 is used to support hot-swapping of the module. It conforms to PICMG AMC.0.

5.2.5. SW3: Boot Mode Select Switch

By setting SW3, the boot source can be selected according to the table below.

Figure 8 – SW500: Boot Mode Select Switch



Table 8 – SW3: Boot Mode Select Switch– Operating Parameters

SW3-1	SW3-2	Function
OFF	OFF	Boot from COMex BIOS
ON	OFF	not supported
OFF	ON	Boot from NAT-AMC-CCT7 carrier SPI
OFF	OFF	bot supported

Note:

Default configuration is labelled with **bold, italic letters**.



6. SPECIFICATIONS AND COMPLIANCES

6.1. Internal Reference Documentation

- NAT-AMC-CCT7

6.2. Standards Compliance

- MTCA.0
- MTCA.4
- AMC.0
- AMC.1
- AMC.2
- IMPI V2.0
- HPM.1

6.3. Compliance to RoHS Directive

Directive 2011/65/EU of the European Parliament and of the Council of 8 June 2011 on the "Restriction of the use of certain Hazardous Substances in Electrical and Electronic Equipment" (RoHS) predicts that all electrical and electronic equipment being put on the European market after June 30th, 2006 must contain lead, mercury, hexavalent chromium, poly-brominated biphenyls (PBB) and poly-brominated diphenyl ethers (PBDE) and cadmium in maximum concentration values of 0.1% respective 0.01% by weight in homogenous materials only.

As these hazardous substances are currently used with semiconductors, plastics (i.e. semiconductor packages, connectors) and soldering tin any hardware product is affected by the RoHS directive if it does not belong to one of the groups of products exempted from the RoHS directive.

Although many of hardware products of N.A.T. are exempted from the RoHS directive it is a declared policy of N.A.T. to provide all products fully compliant to the RoHS directive as soon as possible. For this purpose since January 31st, 2005 N.A.T. is requesting RoHS compliant deliveries from its suppliers. Special attention and care has been paid to the production cycle, so that wherever and whenever possible RoHS components are used with N.A.T. hardware products already.

6.4. Compliance to WEEE Directive

Directive 2002/95/EC of the European Commission on "Waste Electrical and Electronic Equipment" (WEEE) predicts that every manufacturer of electrical and electronic equipment which is put on the European market has to contribute to the reuse, recycling and other forms of recovery of such waste so as to reduce disposal. Moreover this directive refers to the Directive 2002/95/EC of the European Commission on the "Restriction of the use of certain Hazardous Substances in Electrical and Electronic Equipment" (RoHS).

Having its main focus on private persons and households using such electrical and electronic equipment the directive also affects business-to-business relationships. The directive is quite restrictive on how such waste of private persons and households has to be handled by the supplier/manufacturer; however, it allows a greater flexibility in business-to-business relationships. This pays tribute to the fact with industrial use electrical and electronic products are commonly integrated into larger and more complex environments or systems that cannot easily be split up again when it comes to their disposal at the end of their life cycles.

As N.A.T. products are solely sold to industrial customers, by special arrangement at time of purchase the customer agreed to take the responsibility for a WEEE compliant disposal of the used N.A.T. product. Moreover, all N.A.T. products are marked according to the directive with a crossed out bin to indicate that these products within the European Community must not be disposed with regular waste.

If you have any questions on the policy of N.A.T. regarding the Directive 2011/65/EU of the European Parliament and of the Council of 8 June 2011 on the "Restriction of the use of certain Hazardous Substances in Electrical and Electronic Equipment" (RoHS) or the Directive 2002/95/EC of the European Commission on "Waste Electrical and Electronic Equipment" (WEEE) please contact N.A.T. by phone or e-mail.



6.5. Compliance to CE Directive

Compliance to the CE directive is declared. A 'CE' sign can be found on the PCB.

6.6. Compliance to REACH

The REACH EU regulation (Regulation (EC) No 1907/2006) is known to N.A.T. GmbH. N.A.T. did not receive information from their European suppliers of substances of very high concern of the ECHA candidate list. Article 7(2) of REACH is notable as no substances are intentionally being released by NAT products and as no hazardous substances are contained. Information remains in effect or will be otherwise stated immediately to our customers.

6.7. Abbreviation List

Table 9 – Abbreviation List

Abbreviation	Description
AMC	Advanced Mezzanine Card
BIOS	Basic Input/Output System
COM Express	Computer-On-Module Express
DDI	Dual Display Interface
EEPROM	Electrically Erasable PROM
EMC	Electromagnetic Compatibility
FLASH	Non-Volatile Memory
GbE	Gigabit Ethernet
HS	Hot Swap
I ² C	Inter-Integrated Circuit
I/O	Input/Output
IPMB	Intelligent Platform Management Bus
IPMI	Intelligent Platform Management Interface
LTE	Long Term Evolution
μC	Microcontroller
μTCA/MTCA/MicroTCA	Micro Telecommunications Computing Architecture
MCH	μTCA/MTCA Carrier Hub
MMC	Module Management Controller
PCI(e)	Peripheral Component Interconnect (Express)
PrAMC	Processor AMC
(P)ROM	(Programmable) Read Only Memory
SATA	Serial Advanced Technology Attachment
SD-Card	Secure Digital Memory Card
SerDes	Serializer/Deserializer
SGMII	Serial Gigabit Media Independent Interface
SPI (FLASH)	Serial Peripheral Interface (FLASH)
SSD	Solid State Drive
UART	Universal Asynchronous Receiver/Transmitter
USB	Universal Serial Bus
WiFi	Wireless Fidelity – wireless network

7. DOCUMENT’S HISTORY

Table 10 – Document’s History

Rev	Date	Description	Author
1.0	21.09.2021	<ul style="list-style-type: none">initial release	Se
2.0	27.10.2025	<ul style="list-style-type: none">update to hardware revision 2.x	Se
2.1	11.05.2026	<ul style="list-style-type: none">Updated product name and order codes	se

