

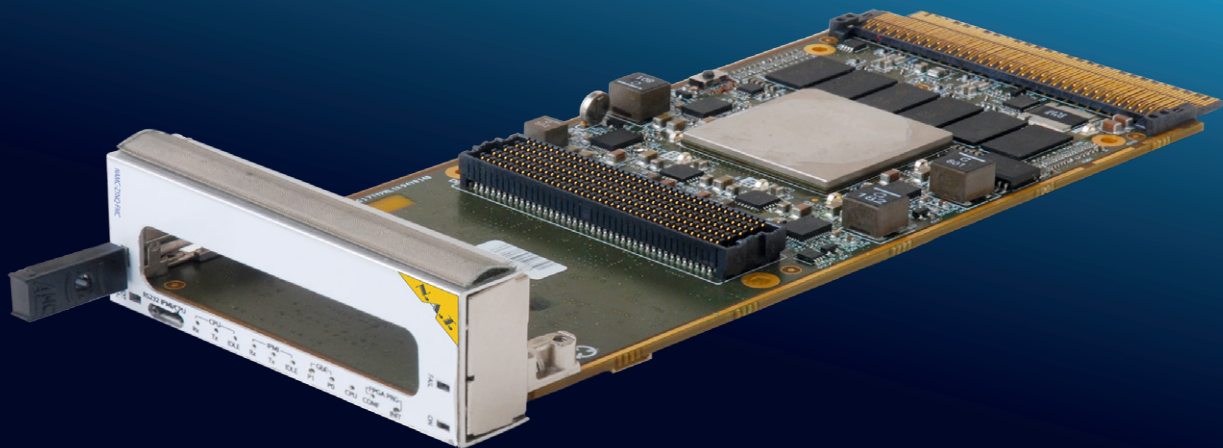

# NAMC-ZYNQ-FMC

## FMC Carrier AMC with Xilinx ZYNQ-7000 FPGA



The NAMC-ZYNQ-FMC is an AdvancedMC (AMC) featuring a Xilinx ZYNQ®-7000 FPGA and an FPGA mezzanine card (FMC) slot. This single-width, mid-size AMC is designed for data acquisition and processing applications and computing nodes. The ZYNQ-7000 FPGA provides the software programmability of an ARM®-based processor with the hardware programmability of an FPGA, enabling key analytics and hardware acceleration while integrating CPU, DSP, ASSP, and mixed signal functionality on a single device.

This module combines that performance with the ability to add functionality through a wide range of off-the-shelf FMCs, including analog-to-digital and digital-to-analog converters, digital I/O and RF modules. N.A.T. can also customize this module to suit your application.

### Key features

- Xilinx ZYNQ-7000 XC7Z045 or XC7Z100 FPGA
- High pin-count FMC slot complies with VITA 57.1
- Dual banks of DDR3 memory (1 GB 64-bit, 512 MB 32-bit)
- 256 MB NOR quad SPI flash memory
- MicroSD card slot
- AMC.1, AMC.2, AMC.3 and IPMI 2.0 compliant
- JTAG access over backplane

### Applications

- Standalone computing node
- Data acquisition
- Signal processing

# Technical Data

## NAMC-ZYNQ-FMC

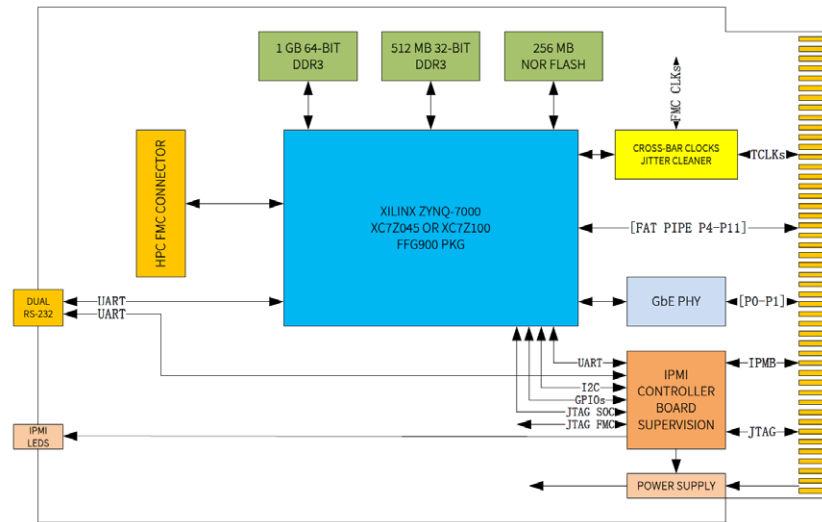

## Overview

The NAMC-ZYNQ-FMC is a single-width, mid-size Advanced Mezzanine Card (AdvancedMC, AMC) designed for data acquisition and processing applications and computing nodes.

It features a reconfigurable system-on-chip (SoC) Xilinx ZYNQ®-7000 FPGA and an FPGA mezzanine card (FMC) slot per VITA 57.1 with supporting interfaces, memory, I/O and data paths optimized to balance performance with flexibility.

### FPGA

The ZYNQ-7000 FPGA provides the software programmability of a dual-core ARM Cortex A9 processor with the hardware programmability of an FPGA, enabling key analytics and hardware acceleration while integrating CPU, DSP, ASSP, and mixed signal functionality on a single device.

### FMC Slot

This module combines that performance with the ability to add functionality through a wide range of off-the-shelf FMCs, including analog-to-digital and digital-to-analog converters, digital I/O and RF modules.

The SoC interfaces directly to the FMC slot via a high pin-count connector and to the MicroTCA backplane using PCI Express, RapidIO (SRIO) or XAUI (10 GbE).

## Memory & Storage

Dual banks of DDR3 memory accessible by both the FPGA and processor sections of the SoC allows for large buffer sizes and queuing during processing. The module offers 1 GB 64-bit and 512 MB 32-bit memory banks.

The module also features 256 MB NOR quad SPI flash memory for fast random read performance and a MicroSD card slot for storage and application code.

## Customization

N.A.T. offers various off-the-shelf customization options such as a full-size front-panel, reduced configurations or FPGA images and can further tailor the NAMC-ZYNQ-FMC to suit your application.

## Specifications

- Single-wide, mid-size AMC (optional full-size front panel)
- Width 73.5mm, depth 180.6mm

### Processing Resources

- System on Chip (SoC) Xilinx Zynq 7000 XC7045 or XC7100 (FFG900 package (31x31mm) (444k LE, 26.5 Mbit internal SRAM, 16 SerDes, 400 I/O, 2k DSP Slices)
- 1 GB 64-bit DDR3 memory
- 512 MB 32-bit DDR3 memory
- 256 MB NOR QSPI Flash memory
- MicroSD Card Slot

### Board Support Package

- Linux boot – Linux Drivers
- AXI4 Wrappers to all external/internal interfaces (soon)
- Design example (soon)
- Documentation

### FMC Site

- Single high pin-count FPGA mezzanine card slot per VITA 57.1
- All differential pairs (LA/HA/HB) routed to the FPGA
- DP0 to DP5 routed to the FPGA

### Front Panel

- Dual UART-USB to ARM core and MMC
- Other connection depend on FMC module used

### Backplane connection

- Full AMC TCLKA-D and FCLKA connectivity
- Dual 1GbE connect to Port 0 and Port 1
- One x8 PCI Express Gen2 connect to Fat-Pipe-Region Ports 4-11 or
- Dual x4 PCI Express Gen2 to Fat-Pipe-Region Ports 4-7 and Ports 8-11 or
- Dual x4 SRIO Gen2 to Fat-Pipe-Region Ports 4-7 and Ports 8-11
- Dual XAUI (10GbE) to Fat-Pipe-Region Ports 4-7 and Ports 8-11 (soon)
- Any Combinations of PCIe, SRIO, XAUI (on request)
- Extended: Ports 12-15 routed to FPGA (2 x 4 LVDS)

### Compliance

- AMC.0 R2.0, AMC.1, AMC.2, AMC.3, AMC.4, IMPI V1.5 & V2.0, HPM.1
- EN60950, UL1950, RoHS

### FMCs supported as standard

- FMC4300
- FMC4301
- FMC4302
- FMC316

N.A.T. is continually developing new FMCs and will check compatibility with the NAMC-ZYNC-FMC. Compatibility of other N.A.T. and third-party FMCs can be verified upon request.